

Tm-RS485-MB / Tm-RS485-MT

Module Temperature Sensor with RS485 Interface



Short Description

Our module and surface temperature sensors come equipped with a stable Aluminium housing and a robust weatherproof cable. Thanks to the use of top quality components the sensors achieve very high accuracy and are ideal for use in field environments (PV module temperature).

All sensors are shipped with a calibration protocol for the measuring amplifier.

If required, the sensors can be ordered with an inspection certificate 3.1 as per DIN EN 10204.

Technical Data

Type	Tm-RS485-MB	Tm-RS485-MT
Interface	RS485	
Protocol	MODBUS	MT
Measuring Range	-40 to +90°C	
Uncertainty (-40 to +90°C)	1 K	
Supply Voltage	24 VDC (10 to 28 VDC)	
Current	Typical 25 mA at 24 VDC	
Galvanic Isolation	1000 VDC between RS485 and Voltage Supply	
Sensor Element	Pt1000 Class A as per EN 60751	
Sensor Housing	Self adhesive Aluminium Block, 35 mm x 12 mm x 6 mm	
Sensor Cable	Length: 3 m, PUR coated, shielded (LiHC11Y, 2 x 0,25 mm ²)	
Case Material	Powder Coated Aluminium	
Case Dimension / Protection Level	98 mm x 64 mm x 34 mm / IP 67	
Weight	approx. 500 g	
Operating Condition	Sensor Element -40 to +90°C (see below Installation Instruction) Case -40 to + 80°C	
Sensor Connection	Length: 6 m, PUR coated, shielded (LiYC11Y, 4 x 0.14 mm ²)	
Customs Number	90 25 19 00	

Tm-RS485-MB / Tm-RS485-MT

Module Temperature Sensor with RS485 Interface

Safety Instructions

The installation and assembly of electrical equipment must be carried out by electrically qualified persons. The sensor may not be used with equipment whose direct or indirect purpose is to prevent human death or injury, or whose operation poses a risk to humans, animals or property.

Electrical Connection

The sensors are designed for safety extra-low voltage (SELV) operation. The cable shield shall be connected to the PE during installation.

WARNING: Connecting the supply voltage to the signal lines will damage the device.

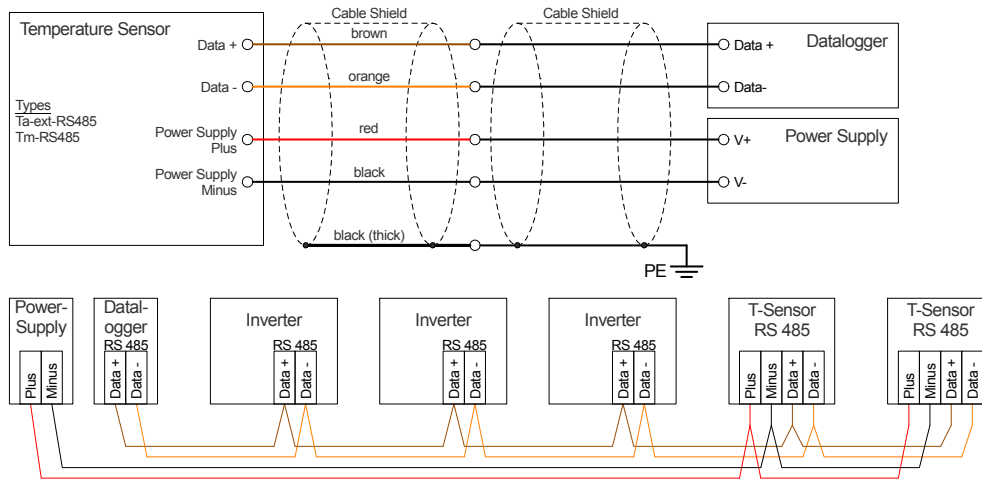

Maximum additional cable length for sensors with 6 m connection cable at voltage supply of 24 VDC / 12 VDC

Cable Cross Section						
0.14 mm ²	0.25 mm ²	0.34 mm ²	0.5 mm ²	0.75 mm ²	1.0 mm ²	1.5 mm ²
300m / 50m	600m / 100m	800m / 150m	1000m / 200m	1000m / 300m	1000m / 400m	1000m / 650m

Installation Instructions

If mounted outdoors, avoid direct exposure to sunlight and rain to the sensor housing (Aluminium block). If necessary, provide protection from the sun and rain.

The through holes used to fix the sensor to a stable and suitable surface shall be accessible when the housing is opened. The tightening torque of the case cover is 180 Ncm.

The sensor element is mounted by gluing the Aluminium block directly to the measurement surface. The surface must be dry, clean and degreased. It is also recommended using an extra fixing with silicon or Sikaflex, particularly for module temperature above 75°C.

Note: The module temperature measurement can be optimised by completely covering the sensor element.

The sensor cable needs a cable grip close to the sensor housing.

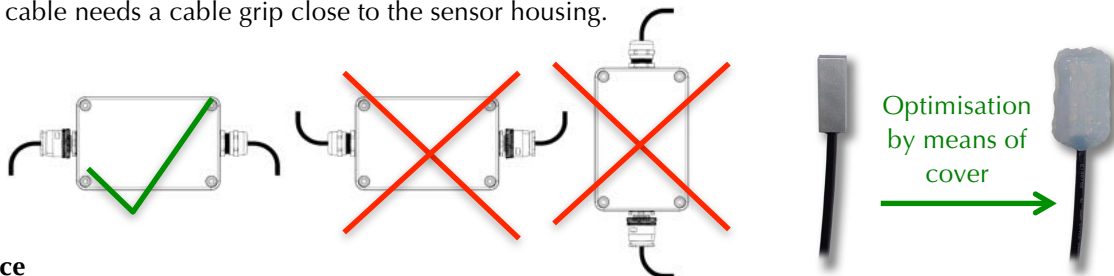

Maintenance

The sensors should be checked once a year for damage, contamination and correct fitting.

Drawing

